

BEHAVIOR OF *BIOMPHALARIA GLABRATA*, THE INTERMEDIATE HOST SNAIL OF *SCHISTOSOMA MANSONI*, AT DIFFERENT DEPTHS IN WATER IN LABORATORY CONDITIONS

P. JURBERG, V.T. SCHALL, J.V. BARBOSA, M.J. GATTI & M.S. SOARES

Instituto Oswaldo Cruz, Departamento de Biologia, Caixa Postal 926, 20001, Rio de Janeiro, RJ, Brasil

Using three columns of different depths (1.10m, 8.40m and 10.40m), we investigated the possibility of *Biomphalaria glabrata* moving towards deep regions. In the 1.10m column, we noted that locomotion can occur in two manners: 1) when the foot is in contact with the substrate: a) sliding descent; b) sliding ascent; c) creeping descent; d) creeping ascent, 2) when the foot is not in contact with the substrate: a) sudden descent without emission of air bubbles; b) sudden descent with emission of air bubbles; c) sudden ascent.

In the 8.40m column containing food on the bottom (experimental group), the snails remained longer at this depth when compared to those of the group which received no food (control). The sliding behavior was characteristic of locomotion occurring at 0 to 1m both in upward and downward directions. Creeping behavior was typical for the ascent of the snails that reached deeper levels. When the snails were creeping, the shell remained hanging as if it were heavier, a fact that may have been due to water entering the pulmonary chamber.

In the 10.40m column, the snails slid downward to a depth of 4m or descended suddenly all the way to the bottom. Ascent occurred by creeping from the bottom to the surface.

In the 8.40m and 10.40m columns, copulation, feeding and oviposition occurred at the deepest levels.

Key words: *Biomphalaria glabrata* – schistosomiasis – behavior

The survival of a few specimens of *Biomphalaria glabrata* at great depths may be one of the causes of the unsuccessful campaigns of molluscicide application to the surface of lakes and reservoirs. Since this species is hermaphroditic and capable of self-fertilization (Brumpt, 1941), a few individuals located in deep regions at the time of application could escape the lethal concentrations of molluscicide and later return to the surface and repopulate the breeding sites.

Deschiens & Jadin (1954) demonstrated that specimens of *Planorbis adowensis* (= *Biomphalaria adowensis*) and *Planorbis glabratus* (= *Biomphalaria glabrata*) survived for 24 days when immersed to a depth of 10m inside boxes and fed at 8 day intervals on the surface.

In view of the lack of data on the ascent and descent of these snails in deep water, we investigated: a) the behavioral patterns of locomotion in a 1.10m glass column; b) the behavioral patterns of locomotion and biological activity in the presence or absence of food in two columns of 8.40 and 10.40m; c) the locomotion and occurrence of biological activities (copula-

tion, feeding and oviposition) in a 10.10m plastic column.

MATERIAL AND METHODS

Twenty specimens of *Biomphalaria glabrata* from Touros, state of Rio Grande do Norte, northeast Brazil, maintained in the laboratory for several generations, were placed in a 1.10m long glass column, 20 in a column located outside the laboratory, and 30 in an internal column located inside a tower. The snails were melanic specimens of 12 to 17mm shell diameter, marked with enamel of different colors and with quick-drying Araldite glue.

Glass column – To determine the behavioral patterns and later define them operationally we used a 1.10m long glass tube 5.5cm in diameter and with a capacity of 1.75 liters. The tube had a tape at the lower end and internal circular plastic platform hanging on nylon threads, which was used to lift the snails up to the surface after the experiment (Fig. 1).

External column – We utilized a transparent polycarbonate plastic column measuring 10.40m in length and 8cm in diameter and having a capacity of 52 liters, located outside the laboratory. The column was filled with water from 2 asbestos tanks, each having a capacity of 100 liters, located in the lower and upper part of the column and interconnected by a Dancor water pump (Fig. 2). Inside the column there were 3 thermometers: one located on the sur-

This investigation received financial support from the UNDP/WORLD BANK/WHO Special Programme for Research and Training in Tropical Diseases, FINEP and CNPq.

Received September 9, 1986.

Accepted May 25, 1987.

face, another at 5 m, and the third at 10.40 m deep. The wall of the column had meter markings to facilitate observation of the animals' locations.

The incidence of sunlight, at noon, on the surface and in the middle of the column produced an artificial light gradient, different from the field. This caused an inadequate temperature gradient. Thus, at the beginning of the observation period at 8:00 A.M., the temperature was 27°C on the surface, 26°C at 5 m and

24°C at 10.40 m; the difference was even more marked at noon, when temperature varied from 40°C on the surface to 42°C at 5 m and 34°C at 10.40 m deep. For this reason we set up another internal column.

Internal column – Inside a 9 m tower we set up a transparent polycarbonate plastic column 8.40 m tall and 8 cm in diameter with capacity for 42 liters. To prevent the snails from falling at the beginning of the experiment, we placed a movable acrylic disk at 5 cm from the surface.

We placed 3 thermometers inside the column: on the surface and at depths of 4 and 8 m. Water temperature during the experiment was 22°C on the surface, 21°C at 4 m and 20°C at 8 m for the experimental group, and 25°C on the surface, 24°C at 4 m and 23°C at 8 m for the control group.

Dissolved oxygen at the surface was 5.34 mg/l for the experimental group and 4.78 mg/l for control group, and pH was 6.66 for the experimental group and 6.54 for the control group measured by Monitor II System, Beckman

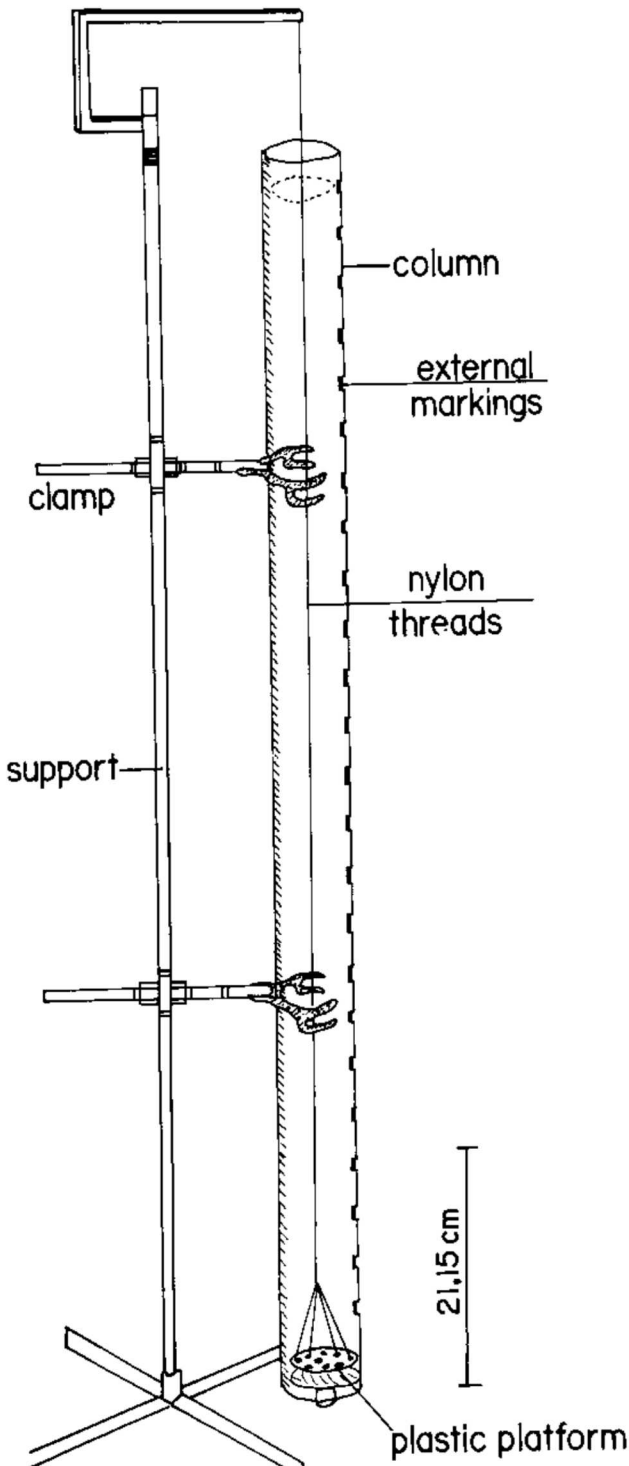

Fig. 1: Schematic drawing of the 1.10m deep glass column.

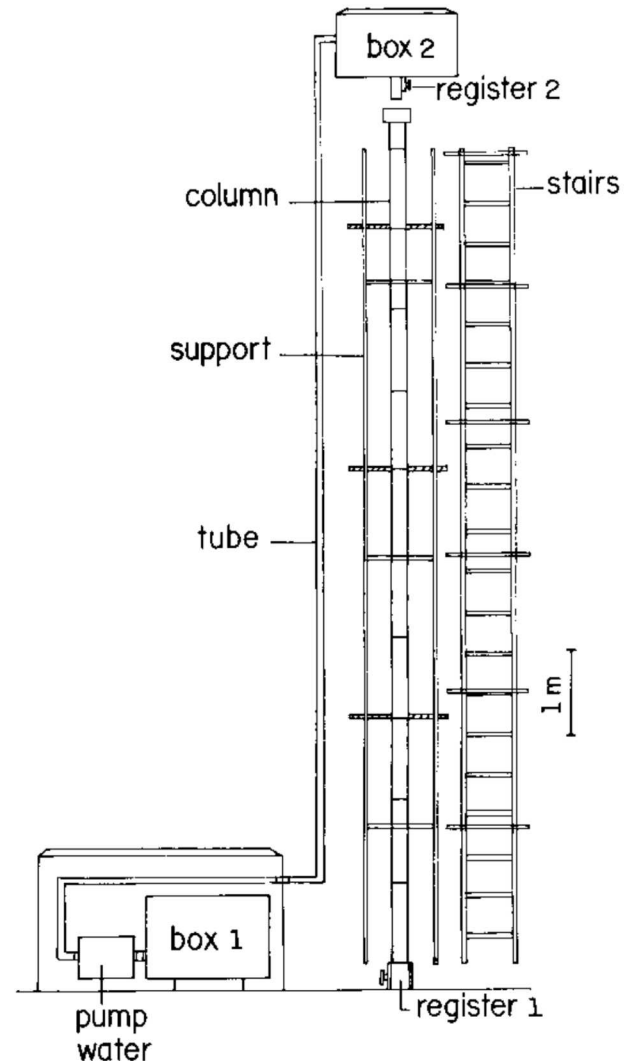

Fig. 2: Schematic drawing of the 10.40m deep external column.

Instruments. Illumination varied from 1.4 to 175 lux throughout the experiment at different times of day, as estimated by a Gossen photometer, model Lunasix 3.

PROCEDURE

Glass column – The glass column was utilized to define the behavioral patterns during observations performed by time sampling (Hall, 1973) for 24 hr. Each sampling lasted 5 min at 30 min intervals (Cunha, 1975, 1976; Ades, 1976).

External column – Behavioral patterns were observed by the same method as used for the glass column, except that each observation lasted 30 min at each 2 hr period between 8:00 A.M. and 2:00 P.M.

Internal column – We utilized 30 snails divided into 2 groups of 15 each: an experimental group (EG – to which 15 disks of lettuce 2.2 cm in diameter were provided as food, attached to a net on the bottom), and a control group (CG – without food). Both groups were fasted for 27 hr.

We utilized a mineral solution for snails (MSS) (Ca = 2.0; Mg = 0.13; Na = 0.63; K = 0.086; Cl = 4.036; HCO₃ = 0.63; SO₄ = 0.13; NO₃ = 0.05; in mM/l) modified from the Standard Snail Water n^o 2 described by Thomas et al. (1976) i.e., having half the original concentration (MSS 1/2), in order to obtain conductivity similar to that of the aquaria where maintained (= 300 umho/cm²).

To study snail distribution and to be able to carry out snail counts, we divided the column into 4 parts with markings: surface (S = 0.00 m); upper part (UP = 0.01 to 0.99 m); middle part (MP = 1.00 to 4.99 m) and lower part (LP = 5.00 to 8.40 m). Both EG and CG animals were observed and behavior was recorded during 30 minute sessions held at 2 hr intervals.

RESULTS

Glass column – The following behavioral patterns were observed:

1. Locomotion

A. With the foot in contact with the substrate: a) *Sliding*: the foot moves in a uniform manner with the sole touching the substrate. The shell is carried in an even and continuous motion. Two subcategories were set up according to the direction of locomotion: sliding ascent (SA) and sliding descent (SD). b) *Creeping*: the foot moves in a uniform or intermittent manner, with the sole touching the substrate. The shell, however, is always carried in an intermittent manner. Two subcategories were set up

according to the direction of locomotion: creeping ascent (CA) and creeping descent (CD).

B. With the foot not touching the substrate: a) *Sudden Descent*: the snail moves downward within the liquid mass, dropping to the bottom with the sole not touching the substrate. This motion originates 2 subcategories: sudden descent, with emission of air bubbles or sudden descent, without emission of air bubbles from the pulmonary chamber; b) *Sudden Ascent*: the snails move upward within the liquid mass, floating up to the surface, with the sole not touching the substrate.

2. Hanging shell – This is characterized by the shell inclined in a position parallel to the cephalopodal mass, with the foot adhering to the substrate. The cephalopodal mass is completely protruded from the shell with the distended neck clearly visible. In this case, the shell is apparently heavier than normal and the locomotion occurs by creeping (Fig. 3).

Three patterns of behavior were observed in still snails in relation to hanging shells. These patterns were established according to the positions of cephalopodal mass: 1) still, with cephalopodal mass in vertical upward; 2) still, with cephalopodal mass in vertical downward; 3) still, with cephalopodal mass in horizontal.

External column

Observations carried out in 2 sessions permitted us to note the following types of locomotion and behavioral patterns: we noticed that 70-80% of the snails descended 10.40m on the sudden descent pattern in the first and second sessions. In both sessions, some specimens descended to 4 m by sliding. All of the specimens which descended to the bottom in both sessions were able to ascend to the surface by creeping or sliding the 10.40m, the former pattern being more frequent than the latter.

We observed feeding as well as copulation at 10.40 m deep; 4 egg masses were found on the surface, one at 8.50m and one at 10.40 m. The egg mass on the bottom contained live embryos up to day 17, when it ruptured and the newly-hatched snails were no longer observable.

Internal column

a) Snail distribution at the different depths of the column during the experiment on the presence or absence of food.

45% and 50% of the experimental and control snails respectively stayed at the surface (Fig. 4).

At the other depths, the percentages found in the upper part (UP), middle part (MP) and lower part (LP), were similar in the control

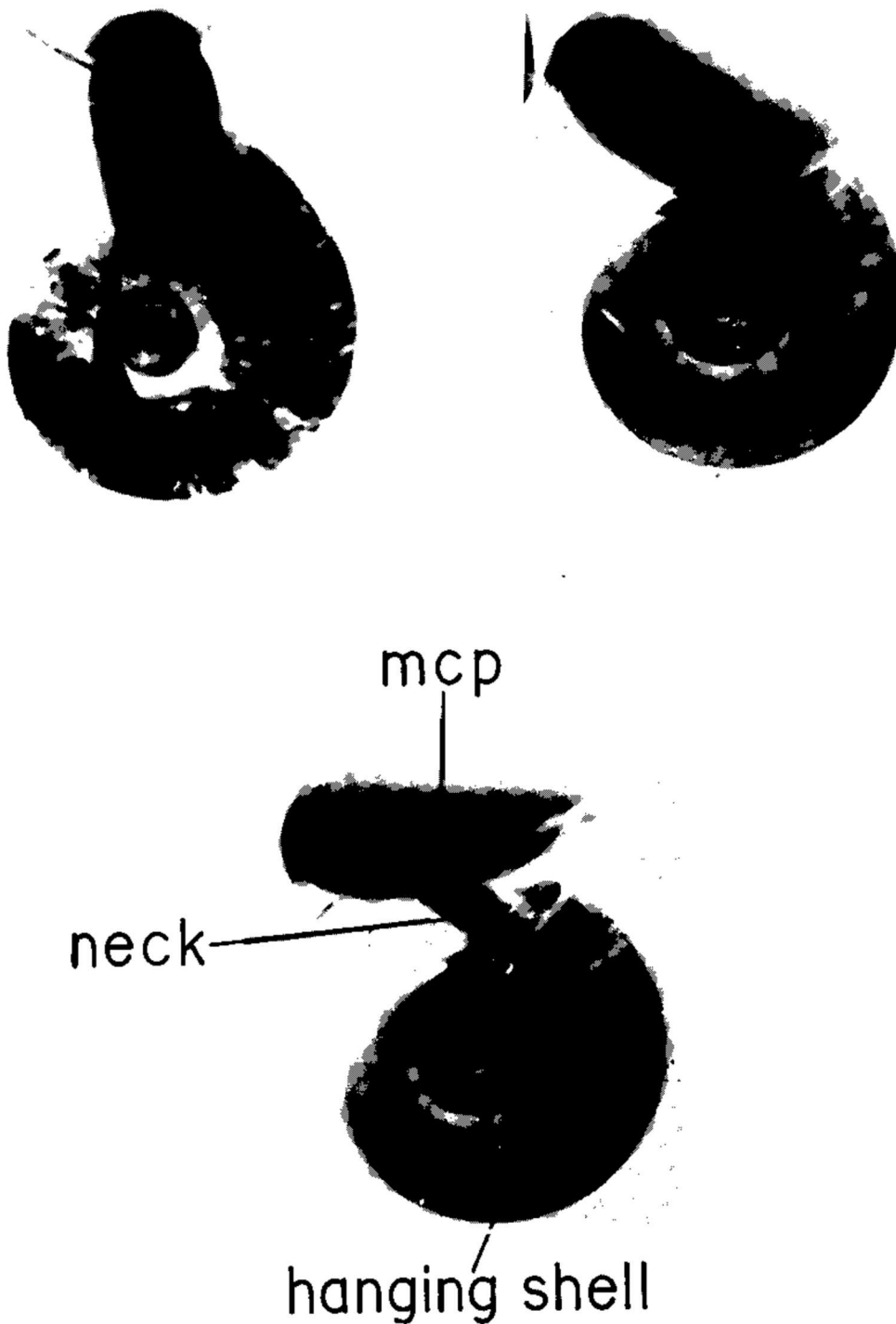

Fig. 3: Sequence of the creep behavioral pattern of *Biomphalaria glabrata*, which can be best visualized in C, where the snail appears with the cephalopodal mass (cpm) fully extended, with the neck exposed arising and the shell hanging.

group, up to 17.8%, 15.4% and 16.4% respectively. However, in the EG, distribution in UP (16.6%) and MP (9.5%) differed from distribution in LP (29.2%). When total number of snails found at the four depths throughout the week were compared by the two way Chi-Square test (Siegel, 1981), a significant difference was obtained between EG and CG ($\chi^2 = 33.72$, d.f. = 4, $p < 0.05$), showing that the distribution of

snails varied with the presence or absence of food on the bottom.

1) When CG and EG were compared (two-classification Chi-Square) considering the total number of observations at each depth of the column, it was seen that (Table 1): (i) the occurrence of snails was significantly greater in CG than in EG, both on the surface and in the middle part of the column; (ii) however, the

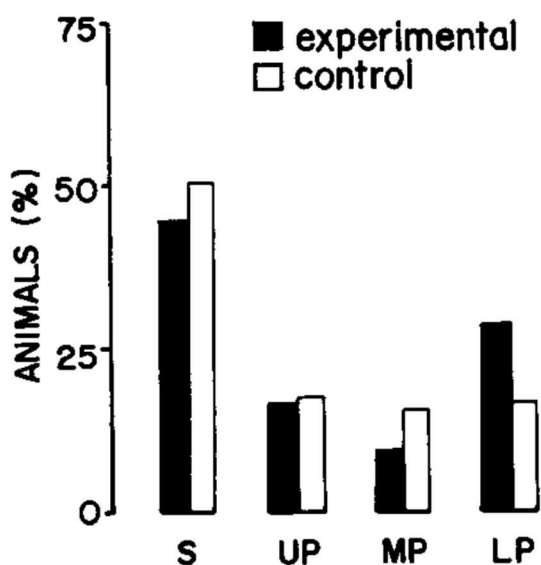

Fig. 4: Distribution (%) of *Biomphalaria glabrata* specimens at various depths of the internal column: S = surface (0.00); UP = upper part (0.01 to 0.99 cm); MP = middle part (1 to 4.99 m) LP = lower part (5 to 8.40 m), during 7 days of experiment ■ Experimental group (food provided at the bottom); □ control group (no food provided).

occurrence of snails in the lower part of the column was significantly greater in the EG than in the CG; (iii) there was no significant difference between EG and CG in the occurrence of the snails in the upper part of the column.

2) As regards the distribution of the snails at daily basis, it can be seen that (Table 1 and Fig.

5): (i) the occurrence of the snails was significantly greater in the EG than in the CG on the surface in the 1st and 7th days and the inverse (CG > EG) in the 2nd and 4th days. On the EG there was a fall in the number of snails from 59% on the first day to 27% on day 4, when the least percent value was registered. In the CG, the least percentage occurred on the 7th day (36.7%) and the fall was observed only from the 5th day; (ii) the occurrence of the snails was significantly greater in the CG than in EG on the upper part in the 3rd and 7th days and in the middle part in the 1st and 2nd days. The lowest EG frequency occurred on the 7th day (5.2%) and the lowest CG frequency on the day 4th (8.9%); (iii) on the lower part the occurrence of the snails was significantly greater in the EG than in CG in the 2nd, 3rd and 4th days.

By summing the number of times when snails stayed still on the bottom throughout the experiment, we recorded 46 occurrences for EG and 26 for GC (Table III).

b) Comparative analysis of the frequency of behavioral patterns of locomotion:

- 1) Sliding Ascent (SA) or Creeping Ascent (CA) and
- 2) Sliding Descent (SD) or Creeping Descent (CD).

When the SA and SD frequencies were compared at a daily basis (Fig. 6A) by the WILCOXON test, the SA pattern was found to be significantly more frequent than SD pattern at the 5% level of significance both for EG (T = 0, N = 7) and CG (T = 0, N = 7).

TABLE I

Frequency of *Biomphalaria glabrata* tested in internal column in the experimental (with food – EG) and control (without food – CG) groups in relation to the days of experiment at various levels

Levels of depth	Surface			Upper part			Middle part			Lower part		
	EG	CG	χ^2	EG	CG	χ^2	EG	CG	χ^2	EG	CG	χ^2
1	58	42	7.46*	26	36	1.44	7	18	4.69*	7	9	0.14
2	49	74	7.11*	17	17	0.06	10	29	9.44*	35	0	44.59*
3	41	54	2.19	9	21	4.85*	10	11	0.00	24	4	18.73*
4	19	52	14.97*	12	8	2.45	13	12	0.82	26	18	5.80*
5	31	44	2.54	14	11	0.69	8	13	0.99	31	22	3.18
6	27	40	1.68	18	12	2.70	9	18	2.22	24	20	1.58
7	44	33	7.00*	4	15	5.42*	0	3	-	29	39	0.55
Totals	269	339	3.91*	100	120	0.30	57	104	10.19*	176	112	29.12*

Surface (0.00); Upper part (0.01 to 0.99 cm); Middle part (1 to 4.99 m); Lower part (5 to 8.40 m). Two-Classificaton Chi-Squares comparisons for each day of experiment and for each level. Asterisks indicate significant differences at the 0,05 level.

TABLE II

Frequency of *Biomphalaria glabrata* in the experimental (EG) and control (CG) groups in relation to the behavioral patterns "sliding descent" and "sliding ascent", "creeping ascent" and "creeping descent", with their location (m) in the 8.40 m deep column during 7 days of experiment

Behavioral Patterns Meters	Sliding				Creeping				
	Descent		Ascent		Ascent		Descent		
	EG	CG	EG	CG	EG	CG	EG	CG	
0.00 – 1.04	31	41	25	22	4	36	2	3	
1.05 – 2.09	5	6	5	5	2	7	0	0	
2.10 – 3.14	4	2	2	1	6	12	0	0	
3.15 – 4.19	2	0	0	0	5	13	0	0	
4.20 – 5.24	0	0	1	0	3	11	0	0	
5.25 – 6.29	0	0	0	0	2	6	0	0	
6.30 – 7.34	0	0	1	0	12	7	0	0	
7.35 – 8.39	1	0	2	1	36	19	0	0	
Totals	43	49	36	29	70	111	2	3	
Test χ^2	1.14				9.28 *				–

χ^2 indicates chi-square values.

TABLE III

Frequency of *Biomphalaria glabrata* in the experimental (EG) and control (CG) groups in relation to the study of spatial disposition of the shell (hanging shell) for following behavioral patterns: (i) still – with the cephalopodal mass in a vertical position and downward and upward; (ii) still – with the cephalopodal mass in a horizontal position; (iii) creeping – with the cephalopodal mass in a vertical position and upward, and their locomotion (m) in the 8.40 m deep column during 7 days of experiment

Meters	Still Vertical Upward		Still Vertical Downward		Still Horizontal		Creeping Vertical Upward	
	EG	CG	EG	CG	EG	CG	EG	CG
	0.00 – 1.04	5	10	0	0	0	1	3
1.05 – 2.09	0	0	0	1	0	0	2	4
2.10 – 3.14	0	1	0	0	0	0	2	10
3.15 – 4.19	2	0	0	0	0	3	5	9
4.20 – 5.24	0	10	1	0	1	4	3	10
5.25 – 6.29	4	13	2	0	3	5	2	6
6.30 – 7.34	1	8	0	0	1	0	10	6
7.35 – 8.39	12	9	6	1	28	16	30	18
Totals	24	51	9	2	33	29	57	89
Text $\chi^2 =$	9.37*		4.55*		0.27		7.01	

χ^2 indicates chi-square values.

The analysis of the daily variation of SA and SD showed respective maximum frequency at 20:00 hr for CG and 22:00hr for EG. Statistical comparison by the MAN-WHITNEY U test showed no significant difference in SD between EG and CG ($U = 32$, $n_1 = 8$, $n_2 = 8$, $p > 0.05$) and in SA ($U = 41.5$, n_1 and $n_2 = 10$, $p > 0.05$, Fig. 6B).

When the number of occurrences of sliding descent (SD), sliding ascent (SA), creeping descent (CD) and creeping ascent (CA), as well as the frequency of staying still was compared (one-classification, Chi-Square) for the entire week of the experiment for both groups (Table II and III) it was seen that: (i) with respect to the behavioral pattern of sliding descent and

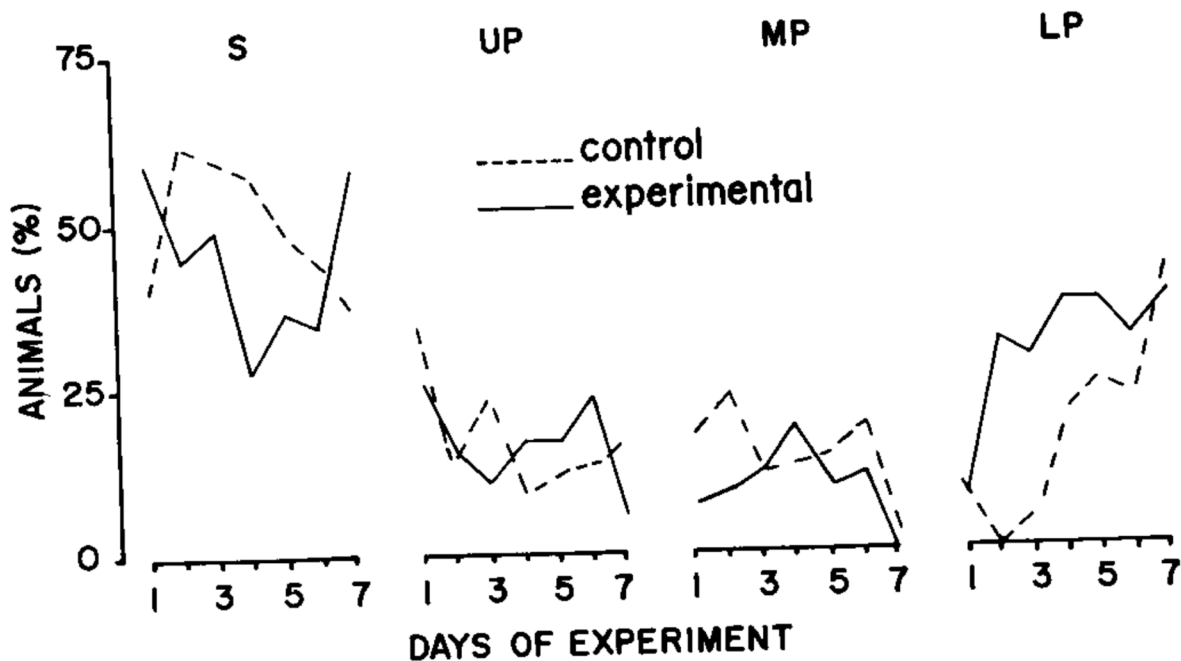

Fig. 5: Daily frequency (%) of *Biomphalaria glabrata* specimens at various levels of the experimental column: S = surface (0.00); UP = upper part (0,01 to 0,99 cm); MP = middle part (1 to 4,99 m); LP = lower part (5 to 8,40 m), during 7 days of experiment.

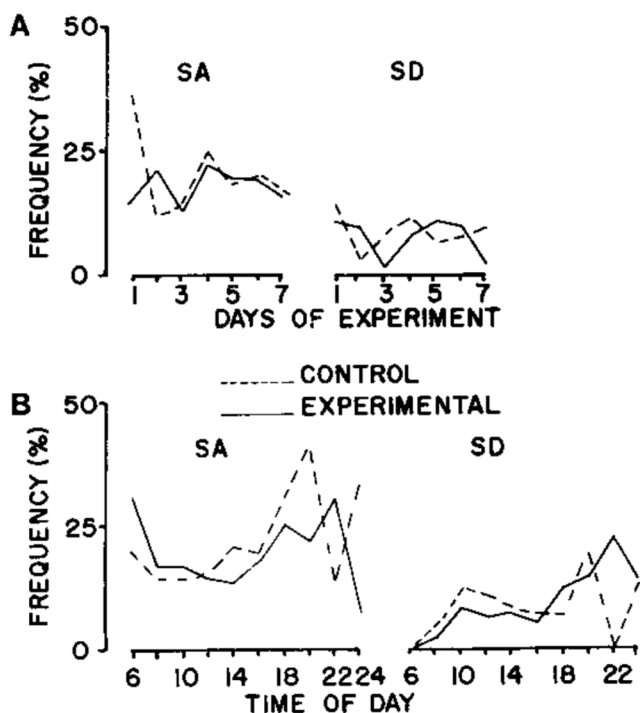

Fig. 6: Frequency (%) in *Biomphalaria glabrata* of sliding ascent (SA) and sliding descent (SD) per day (A) and per hour (B) of experiment.

sliding ascent, EG animals showed no significant differences ($\chi^2 = 0.620$; d.f. = 1; $p > 0.05$). In CG animals, however, sliding descent occurred at significantly greater extent than sliding ascent ($\chi^2 = 5.128$; d.f. = 1; $p < 0.05$). Comparison between EG and CG for both patterns (SD and SA) showed no significant difference (Table II); (ii) when the frequencies of the creeping ascent and creeping descent were compared, the occurrence of creeping ascent was significantly greater than creeping descent, both in EG ($\chi^2 = 61.2$; d.f. = 1; $p < 0.001$) and CG ($\chi^2 = 82.4$; d.f. = 1; $p < 0.001$).

Comparison between EG and CG for creeping ascent showed that CG is significantly greater than EG. The short frequency for the creeping descent both in EG and CG permitted no statistical treatment (Table II).

c) Relationship between hanging shell and creeping ascent and staying still.

Hanging shell was observed most frequently when the animals crept ascent, especially at the deeper levels. Even snails standing still, with the cephalopodal mass oriented upward, had their

shells in this position at high frequencies when they were located at the deeper levels.

The pattern of staying still with hanging shell was analysed in three positions: still vertical upward, still vertical downward and still horizontal. Comparison between EG and CG for each position showed that the frequencies of EG were significantly greater than those of CG for the still vertical downward and the inverse for the still vertical upward. No difference was found for the still horizontal (Table III). When the creeping vertical ascent pattern was analysed in association with the hanging shell pattern, significantly greater frequencies were found for the CG than for the EG (Table III). Comparison of the total frequency of the creeping ascent pattern (Table II) with the total frequency of creeping vertical ascent with hanging shell (Table III) demonstrated that this pattern (creeping ascent) was frequently associated with the occurrence of hanging shell.

d) Occurrence of behavioral patterns of locomotion at the different column levels.

We found that: 1) Sliding descent was more frequent up to 1.04 meters (72.1% for EG and 83.7% for CG), with only a single case occurring in EG between 7.35 and 8.39 m (2.3%); 2) Sliding ascent was more frequent for CG than for EG up to 1.04 m (69.4% for EG and 75.9% for CG), with only 3 cases observed between 7.35 and 8.39 m (one CG specimen (3.4%) and two EG specimens (5.5%) – Fig. 7; 3) Creeping ascent occurred at higher frequency in CG (23.1%) than in EG (4.5%) between 0.00 and 1.04 m. Between 7.35 and 8.40 m, however, creeping ascent was more frequent in EG

(49.3%) than in CG (19.8%); 4) Creeping descent was observed only 5 times (2 in EG and 3 in CG) at the surface, and was even less frequent at the remaining levels (Table II – Fig. 7).

e) Other observations

EG animals consumed the entire amount of food up to the 4th day and copulated at depth of 8.40m.

DISCUSSION

The possibility of planorbids being able to descend, ascend and perform biological activities such as copulation, oviposition and feeding in regions other than the surface should be taken into account in control campaigns, since these abilities may permit them to move to deeper sites, increasing their probability of survival. However, little attention has been paid to the fact that these molluscs may survive at greater depths in water basins, since their habitat is usually considered to be shallow waters (Paraense & Santos, 1953; Andrade, 1959; Paraense, 1970; Freitas, 1976; Appleton, 1978) where control programs are usually carried out.

Other investigators have reported the presence of planorbids in deeper waters: Mandahl-Barth (1954) found *B. smithi* at a depth of 4.3m in Lake Edward (Uganda) and *B. choanomphala* at 12.2 m in Lake Victoria; Hubendick (1955) and Haas (1955) reported the presence of *Taphius heteropleurus* (*B. = heteropleura*) in Lake Titicaca (Peru) at a depth of 79 to 82 meters; Rey (1956) reported that it was possible to find planorbids up to 5 m depths; Freitas (1976) found *B. glabrata* on the bottom of Lagoa Santa (State of Minas Gerais, Brazil), which

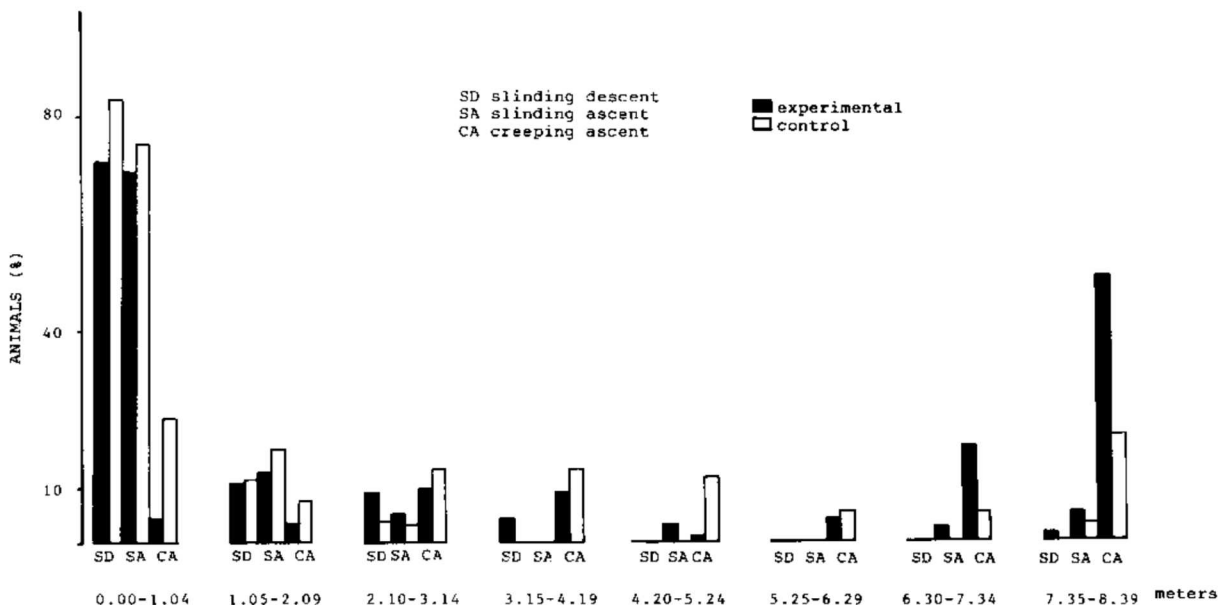

Fig. 7: Frequency (%) of *Biomphalaria glabrata* in relation to behavioral patterns and their locomotion (m) in the 8,40 m deep column during 7 days of experiment.

is 4 to 5 m deep. Also Appleton (1978) found *B. pfeifferi* at 4.5 m.

Deschiens & Jadin (1954) working with *B. glabrata* and Gillet et al. (1960) working with *B. pfeifferi* in analogous experiments found that these planorbids can respectively survive 24 and 31 days when submerged in boxes at a depth of 10 m (*B. glabrata*) and 15.25 m (*B. pfeifferi*). However, Appleton (1978) considered these experiments inconclusive because of the impossibility of repeating them, the small number of animals and the manner the studies were conducted. In our opinion, Appleton's criticism does not invalidate the importance of the results, since *B. glabrata* belongs to hermaphroditic species capable of self-fertilization. Thus, a few specimens surviving adverse conditions would be sufficient to repopulate the breeding sites (Paraense, 1972).

The fact that these snails preferentially live in superficial water layers may be related to their pulmonary system. However, they also have a pseudobranch which may represent an alternative respiratory system. The pseudobranch may be related to animal's survival in deep waters even when they can not reach the surface, as observed by Jurberg et al. (1982), who maintained *B. glabrata* specimens under these conditions for 92 days.

Glass column

The glass column permitted us to analyse the locomotive patterns of behavior and classify them on the basis of the contact of the sole with the substrate. These modes of behavior had also been observed by Townsend (1975), who, however, only described 4 categories without reporting the circumstances of occurrence. In the present study we established 7 categories and related their occurrence to the different levels of the column, and we also described the occurrence of a pattern denoted "hanging shell" which was related to creeping ascent at deeper locations.

External column

The external column was deactivated after 2 experiments because its location permitted sunlight to reach the 6 m level, thus generating a thermal gradient which does not occur in nature. An additional problem was that the snail, when placed on the surface, might have fallen to the bottom instead of performing sudden descent, a fact that would explain the high ratio of downward locomotions recorded. This column, however, permitted us to observe feeding, copulation and egg-masses at 10.40 m deep.

Internal column

a. Snail distributions at different depths of the

column Corr et al. (1984), in a study of vertical locomotion of *B. glabrata* in 15 cm deep containers with lettuce on the bottom, noted that the snails spent 58% of their time feeding on the bottom, 35% on the surface, and only 7% at the other two intermediate levels. In the internal column, we obtained a different distribution, with higher frequency on the surface (50% in the control group and 45% in the experimental group). The frequencies detected for the lower part (5 to 8.40 m) were 29.2% for EG and 16.6% for CG. The low frequency of animals found in both groups, in the upper and middle parts (below 17.8%), indicates that these are only transition levels for the animals. The discrepancy between our data and those reported above is probably due to the great difference in the depth of the experimental equipments. The fact that the frequency of location in the lower part was significantly higher for EG than for CG does not mean that food attracted the snails, since they could have moved to the bottom at the same frequency in both situations (with and without food), but remained longer on the bottom of the EG column due to the presence of food, thus causing a greater frequency of observations in this group (84 times in EG as opposed to 36 in CG). Furthermore, data obtained in studies using attractants have ruled out the possibility of chemical orientation responses at a distance. Studies by Michelson (1960), Townsend (1974), Thomas (1977) and Bousfield (1979) have concluded that *B. glabrata* is able to respond by orientating towards chemical substances or certain types of food. However, Townsend (1973) demonstrated that these oriented responses occur within a very limited area around the snail (approximately 2.5 cm).

By examining the daily frequencies at the 4 levels of the column we noted in the upper and lower parts significant differences between EG and CG on the surface. These differences may be attributed to the fact that the EG snails that descended spent a longer time feeding on the bottom, an activity that lasted until the 4th day, when the food was completely consumed. No significant differences were observed between groups in the middle part, indicating that this may just be a transit region between the others.

b. Analysis of the behavioral patterns of locomotion — When the daily frequencies of slinding ascent and descent were compared, the number of ascent was found to be greater than the number of descent. This is apparently contradictory since, in order to ascend, the snails would have to descend at the same proportion. However, the difference may have been due to sudden descents that were not recorded due to

the observation technique used (30 min out of each 2 hr period). Sudden descent is much faster, and so is sudden ascent, and these two patterns were occasionally observed during the recording sessions. In addition to these occasional observations, snails which were observed on the surface at the end of a session were found in the lower part at the beginning of the next session (2 h later), indicating faster locomotion than by sliding descent.

Townsend (1975), studying the influence of food deprivation on ascent and descent at 20 cm of depth in *B. glabrata*, added the number of times the snails descended and ascended in 3 experiments performed over a period of 4 days under three conditions: in the absence of food and in the presence of two different amounts of food. In a total of 420 descents, from the surface, 414 were by crawling down touching the container and 6 by dropping without touching the container. Of the 420 ascents 308 were by crawling up and 112 by floating up.

These results differ from those obtained by Corr et al. (1984), in a 15 cm deep column with lettuce on the bottom. They found that passive floating up or dropping movements were 21% in relation to the 14% reported by Townsend (1975).

The present results also demonstrated that there is a great frequency of motion by sliding and creeping. However, they cannot be compared quantitatively to those reported above because the columns utilized by us were much deeper, the descriptions of the locomotion patterns were much less detailed than in the present study and by our observation method the sudden ascent and descent were not quantified.

The experiments in the external column gave different results from those obtained in the internal column, since the great majority of descents was sudden. This kind of locomotion may be due to the fact that the snails were placed on the upper part of the column without a screen and were not given time to adhere to the substrate. This fact did not occur in the internal column because of the screen.

Rey (1956) argued that the descent is due to the fact that the air bubble come out of the pulmonary chamber. However, our observation in the glass column showed that this behavior also occurs without any loss of air, a phenomenon that may be explained by a shrinking of the cephalopodal mass and of the pulmonary chamber, so that a consequent decrease in volume would increase the specific weight of the animal and thus lead to sudden descent.

Henderson (1963) found no evidence in *Lymnaea stagnalis* and *Planorbis corneus* that

the adjustment of floating is due to gas secretion or to compression of the air bubble during submersion. However, we may assume that the latter mechanism is present in *B. glabrata*, since this would be a way to explain the sudden ascent. Snails at the bottom of container may reduce their specific weight by distending the cephalopodal mass and increasing their volume (Archimedes principle), thus being able to float up to the surface. Distention and contraction of the pulmonary chamber filled with air would permit them to move without great effort, as observed in the sliding descents and ascents. This hypothesis, however, should be tested experimentally and considered with caution, since there is also the possibility that snails with a chamber full of air may descend to a given depth, detach the foot from the substrate and ascend due to the air bubble independently of the distention of the cephalopodal mass. Cheatum (1934) postulated the mechanism involved in changing the specific weight by contraction or relaxation of the pulmonary sac as causing descent in snails of the families Physidae and Lymnaeidae and in *Helisoma trivolvis*.

Pimentel & White (1959) showed the occurrence of vertical migrations under field conditions. They observed that there was a large number of snails on the surface at night than during the day. They confirmed a progressive decrement in number of snails on the surface at 6:00 A.M. and an increase which began at 6:00 P.M. and reached maximal values about midnight, at laboratory conditions.

These data indicated the possibility of occurrence of various distribution patterns at different daytimes. Our data demonstrated similar results. The highest locomotion rate was noticed during dusk. The same results had been reported by Pimentel & White (1959), Pimentel Souza et al. (1976, 1984), Schall (1980), Rotenberg et al. (in press).

c) Analysis of the relationship between a hanging shell and creeping ascent and staying still – A hanging shell was observed in snails which reached and remained at greater depths and was always associated with creeping motion, thus representing additional evidence for the entry of water into the pulmonary chamber. This phenomenon was also observed by Jurberg et al. (1982) after 48 hours in experiments in which the snails were prevented from reaching the surface.

d) Occurrence of behavior of locomotion at the different levels of the column – The sliding behavior occurred mainly at 0 to 1 m both in the upward and downward directions (in CG and EG). Probably the snails are able to control

the specific weight and water did not enter into the pulmonary chamber at these levels.

The creeping behavior and hanging shell were more frequent at deep levels of the column in EG. There is the possibility that water gets into the pulmonary chambers and the snails are not able to control the specific weight.

In the control group we noticed the creeping ascent distributed all along the length of the column. This fact probably occurred because the snails spent time to descend to the bottom and not finding food there, they returned to the surface.

Two factors could influence the probable entry of water into the pulmonary chamber: the time spent submerged and water pressure. Jurberg et al. (1982) reported that *B. glabrata* impeded to come to the surface after 12 – 86 hours showed creeping locomotions and hanging shell.

The possibility of the entering of water into the pulmonary chamber in *B. glabrata* has been suggested in histological study by Sullivan & Cheng (1974). But all these evidences about the possibility of entering water into pulmonary chambers are indirect.

RESUMO

Comportamento de *Biomphalaria glabrata*, caramujo hospedeiro intermediário do *Schistosoma mansoni*, em diferentes profundidades da água sob condições de laboratório – Investigamos a possibilidade de *Biomphalaria glabrata* deslocar-se para regiões profundas, em três colunas de diferentes profundidades (1,10 m, 8,40 m e 10,40 m). Na coluna de 1,10 m evidenciamos que os deslocamentos podem ser de duas maneiras: 1) Quando o pé está em contato com o substrato: (i) deslizar para baixo; (ii) deslizar para cima; (iii) arrastar para baixo; (iiii) arrastar para cima. 2) Quando o pé não está em contato com o substrato: (i) descida súbita sem saída de bolhas de ar; (ii) descida súbita com saída de bolhas de ar; (iii) subida súbita.

Na coluna de 8,40 m em que havia alimento no fundo (grupo experimental) observamos que os caramujos permaneceram maior tempo nesta profundidade em relação ao grupo que não recebeu alimento (grupo de controle). Verificamos que o comportamento de deslizar é característico dos deslocamentos em torno de 0 a 1 m, tanto para subir como para descer. O comportamento de arrastar foi típico de subida dos caramujos que atingiram níveis mais profundos. Quando os caramujos arrastavam-se a concha ficava pendente como se estivesse mais pesada, o que pode estar relacionado à entrada de água na câmara pulmonar.

Na coluna de 10,40 m verificamos que os caramujos deslizavam para baixo até 4 m ou apresentavam descidas súbitas até o fundo. As subidas se davam pelo padrão comportamental denominado arrastar, do fundo até a superfície.

Nas colunas de 8,40 e 10,40 m verificamos cópula, alimentação e desova nos níveis mais profundos.

Palavras-chave: *Biomphalaria glabrata*
esquistosomose – comportamento

ACKNOWLEDGMENTS

Our thanks to Marta de Azevedo Irving for her participation in one of the experimental phases of this work and to Dr. W. Lobato Parraense and Dr. Otavio Sarmiento Pieri for their invaluable criticism.

REFERENCES

- ADES, C., 1976. A observação do comportamento em situações experimentais. *Ci. e Cult.*, 28 (1) :25-34.
- ANDRADE, R.M., 1959. Ecologia. *Rev. Bras. Mal. D. Trop.* 11 (2/3) :171-217.
- APPLETON, C.C., 1978. Review of literature on abiotic factors influencing the distribution and life cycles of bilharzias intermediate host snails. *Malacological Review*, 11 :1-25.
- BOUSFIELD, J.D., 1979. Plant extracts and chemically triggered positive rheotaxis in *Biomphalaria glabrata* (SAY), snail intermediate host of *Schistosoma mansoni* (SAMBON). *J. Appl. Ecol.*, 16 :681-690.
- BRUMPT, E., 1941. Observations biologiques diverses concernant *Planorbis (Australorbis) glabratus*, hôte intermédiaire de *Schistosoma mansoni*. *Ann. Parasit. Hum. Comp.*, 18 :9-45.
- CHEATUM, E.P., 1934. Limnological investigations on respiration, annual migratory cycle, and other related phenomena in freshwater pulmonate snails. *Trans. Am. Microscop. Soc.*, 53 :348-407.
- CORR, M.; COVICH, A. & YOSHINO, T.P., 1984. Vertical movement and time allocation of a freshwater pulmonate snail. *Hydrobiologia*, 112 :69-72.
- CUNHA, W.H.A., 1975. O estudo etológico do comportamento animal. *Ci. e Cult.*, 27 (3) :262-268.
- CUNHA, W.H.A., 1976. Alguns princípios de categorização, descrição e análise do comportamento. *Ci. e Cult.*, 28 (1) :15-24.
- DESCHIEENS, R. & JADIN, J., 1954. Viabilité des mollusques vecteurs des bilharzioses dans les eaux profondes. *Bull. Soc. Path. Exot.*, 47 (3) :668-671.
- FRÉITAS, J.R., 1976. Ecologia de vetores de doenças. O habitat primitivo da *Biomphalaria glabrata*. *Ci. e Cult.*, 28 (2) :212-217.
- GILLET, J.; BRUAUX, P. & WOLFS, J., 1960. Resultats de prospections malacologiques en profondeur au lac Kivu et recherches sur la survie de *Biomphalaria* en eau profonde. *Ann. Soc. Belge de Med. Trop. Bruxelles*, 40 :643-649.
- HAAS, F., 1955. The Percy Sladen Trust Expedition to Lake Titicaca in 1937. XVII. Mollusca: Gastropoda. *Trans. Linn. Soc. Lond.*, 1 (3) :275-308.
- HALL, R.V., 1973. Manipulação do comportamento.

- Modificação de comportamento: A mensuração de comportamento.* Trad. Waldir Bettoi, EPU-Ed. Universidade de São Paulo.
- HENDERSON, A.E., 1963. On the underwater weights of freshwater snails. *Z. Vergl. Physiol.*, 46 :467-490.
- HUBENDICK, B., 1955. Percy Sladen Trust Expedition to Lake Titicaca in 1937. XVIII. The anatomy of Gastropoda. *Trans. Linn. Soc. Lond.* 1 (3) :309-327.
- JURBERG, P.; GATTI, M.J.; SOARES, M.S. & BARBOSA, J.V., 1982. Comportamento e condições de sobrevivência de *Biomphalaria glabrata* submetida a imersão prolongada. *Ci. e Cult.*, 34 (7) :802-Suplemento.
- MANDAHL-BARTH, G., 1954. The freshwater mollusks of Uganda and adjacent territories. *Ann. Mus. R. Congo Belge. Ser. in 80, Sci. Zool.*, 32, 206 p.
- MICHELSON, E.W., 1960. Chemoreception in the snail *Australorbis glabratus*. *Am. J. Trop. Med. Hyg.*, 9 :480-487.
- PARAENSE, W.L., 1970. Planorbídeos hospedeiros intermediários do *Schistosoma mansoni*, p. 13-30. In: A.S. Cunha, *Esquistossomose mansoni*. São Paulo, Sarvier e Univ. São Paulo.
- PARAENSE, W.L., 1972. Fauna planorbídica do Brasil, p. 213-239. In: C.S. Lacuz et al., *Introdução à Geografia Médica do Brasil*. Blücher e Univ. São Paulo, São Paulo.
- PARAENSE, W.L. & SANTOS, J.M., 1953. Um ano de observações sobre esquistossomose em planorbídeos da Lagoa Santa. *Rev. Bras. Malariol. D. Trop.*, 5 (3) :253-269.
- PIMENTEL, D. & WHITE, P.C., 1959. Biological environment and habits of *Australorbis glabratus*. *Ecology*, 40 (4) :541-550.
- PIMENTEL-SOUZA, F., FERNANDES-SOUZA, N., SCHALL, V.T. & COELHO P.M.Z., 1976. Comportamento elementar do caramujo *Biomphalaria glabrata*. I - Disposição espacial da concha. *Rev. Bras. Biol.*, 9 (2-3) :117-122.
- PIMENTEL-SOUZA, F.; SCHALL, V.T.; LAUTNER, Jr. R.; BARBOSA, N.D.C.; SCHETTINO, M. & FERNANDES, N., 1984. Behavior of *Biomphalaria glabrata* (Gastropoda: Pulmonata) under different lighting conditions. *Canadian J. Zool.* 62 :2328-2334.
- REY, L., 1956. Contribuição para o conhecimento da morfologia, biologia e ecologia dos planorbídeos brasileiros transmissores da esquistossomose. Serviço Nacional de Educação Sanitária, Rio de Janeiro. xiii + 217 p.
- ROTFENBERG, L., JURBERG, P. & PIERI, O.S., (in press). Relationship between lighting conditions and behavior of the freshwater snail *Biomphalaria glabrata*, intermediate host of schistossomias. *Hydrobiologia*.
- SCHALL, V.T., 1980. *Comportamento de caramujo Biomphalaria glabrata em um gradiente luminoso*. Tese de Mestrado. Departamento de Fisiologia e Biofísica. ICB-UFMG. Belo Horizonte-MG, 82 p.
- SIEGEL, S., 1981. Estatística não-paramétrica. Mc Graw-Hill. 1-350 p.
- SULLIVAN, J.T. & CHENG, T.C., 1974. Structure and function of the mantle cavity of *Biomphalaria glabrata* (Mollusca: Pulmonata). *Trans. Amer. Micros. Soc.*, 93 (3) :416-420.
- THOMAS, J.D., 1977. The sociobiology of *Biomphalaria glabrata*, the snail host of *Schistosoma mansoni*. Excerpta Parasitologica en Memoria del doctor Eduardo Caballero. J. Caballero. *Instituto de Biología Publicaciones Especiales*, 4 :531-542.
- THOMAS, J.D.; POWLES, M. & LODGE, R., 1976. The chemical ecology of *Biomphalaria glabrata*: The effects of ammonia on the growth rate of juvenile snails. *Biol. Bulz*, 151 :386-397.
- TOWNSEND, C.R., 1973. The food-finding orientation mechanism of *Biomphalaria glabrata* (SAY). *Anim. Behav.*, 21 :544-548.
- TOWNSEND, C.R., 1974. Mucus trail following by the snail *Biomphalaria glabrata* (SAY) *Anim. Behav.*, 22 (1) :170-177.
- TOWNSEND, C.R., 1975. Strategic aspects of time allocation in the ecology of a freshwater pulmonate snail. *Ecologia*, 19 :105-115.